

Operating instructions for the MOTO-DETAIL Luggage Set ITEM CODE: 10025335

1.) Open side bags and insert the short reinforcement sheets at the bottom and the long ones at the top into the guides. They need to fit tightly into their positions. If necessary, adjust their width with a carpet knife.

2.) Decide if you want to position the bridge plate (see diagram 2) on top or under the pillion seat. In general, it is better to fit the bridge plate under the pillion seat, but you need to choose the widest area so on a naked sports bike it may be best placed over the pillion seat. If used over the seat, use the straps to secure the bridge plate underneath.

Position the side bags on the side with the exhaust(s) so that they clear the top of the exhaust by 2-2.5" fully laden. Based on that, adjust the click links on the back of the bag and the straps that hold the bags. Always perform this check before journeys and make sure that the clearance is maintained with the suspension compressed under full body weight.

Protect painted areas with Invisible Foil or another form of protective underlay.

3.) Now use the straps to secure the bags as required to foot rests and /or other fixing points (see dia. 3). If the straps need to be shortened then cut them and seal the edge with a lighter flame.

4.) The luggage roll can be click-fastened to the bridge plate. If used separately, simply attach to seat using the straps or use with the bridge plate (we recommend the latter). Please always ensure that the luggage roll has some stability about itself once packed - it should not 'flop' on one side or allow heavy objects to move from left to right. The max. load is 5KG and heavy objects must be placed in the centre of the roll.

5.) Pack bags evenly to ensure balance and stability at speed. You can adjust the side bag volume using the zip adjustments and the ratchet straps (see dia. 1).

6.) In rain please protect carried items separately with specialist rain covers or simply plastic bags. Outer rain covers are included in the delivery but please note that outer rain covers are not suitable for long distances at high speed - they are just for protection in an unexpected downpour.

7.) The bags can be cleaned with warm soapy water. Please use textile protector spray in addition to keep them looking good.

8.) Adjust your travel speed according to your luggage and load!

Take the time to fit the bags properly. Inappropriate attachment or handling not only voids any product guarantees but can also lead to lost luggage or accidents.

Operating instructions for the MOTO-DETAIL Luggage Set ITEM CODE: 10025335 - PAGE 2

Safety Recommendations:

GetGeared recommends the use of panniers ONLY with fitted side spacer that keep bags securely away from the moving parts of the bike. Always ensure that bags and ties do not interfere with chain, wheels or other moving parts and that sufficient distance is maintained to the exhaust. Never attach the bags to parts of the bike that swing with the movement of the suspension or the suspension coil itself.

Load bags evenly and do not overload (maximum 5KG per bag). Inappropriate packing or attachment can lead to dangerous imbalances while driving and potentially to an accident.

Do not exceed a speed of 65mph (where allowed), even with properly loaded and secured bags. Adjust your driving style to the additional load and overhang you're carrying!

PANNIERS - DIAGRAM 1

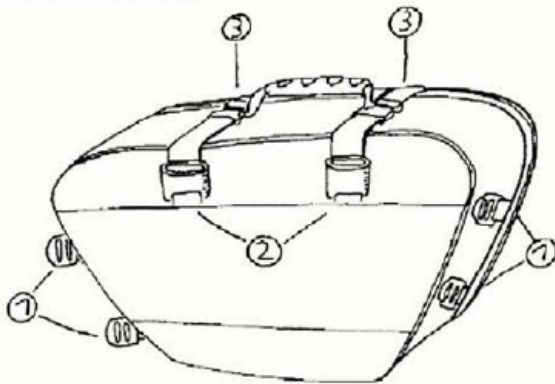

- 1.) Short strap fittings
- 2.) Push connectors to bridge plate
- 3.) Adjustable straps to vary bag volume

BRIDGE PLATE - DIA. 2

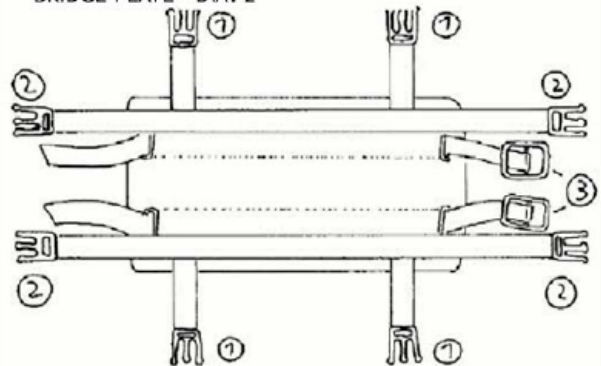

- 1.) Adjustable push connectors for speed bag
- 2.) Adjustable push connectors for panniers
- 3.) Adjustable straps for securing bridge plate to bike

DIA. 3

